

# SINO

## INSTALLATION MANUAL



# SINO

## PRECAUTIONS

Before commencing the installation it is important to read this section first.

### Travel Length

1. The travel length of the glass graduated scale must be longer than the maximum travel of the machine, there should be at least 10mm clearance between the ends of the glass scale and the maximum travel of the machine as shown in Fig. 1

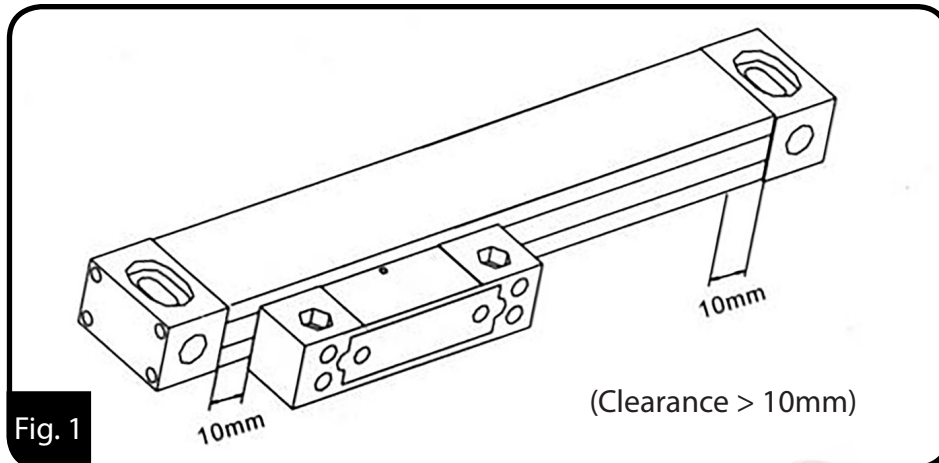

### Mounting Selection

2. To ensure the graduated glass scale to be installed is reliable, and to avoid any possibility of the scale misalignment, the scale should be installed on a machined flat surface of the machine wherever possible. In the case where there are no machined flat surfaces available, optional backing plates are available and should be used. Wherever possible the scale ends and the reader head should be installed on a flat surface.

### Alignment

3. When using a lever dial indicator to align the scale, it is important to ensure that the angle between the Indicator lever tip and the surface being measured must be less than  $30^\circ$  to avoid a cosine measurement error. If a vertical dial indicator is used as per the following figures shown, it is important to ensure that the dial indicator is perpendicular to the measured surface to also avoid the cosine measurement error. (Fig. 2)

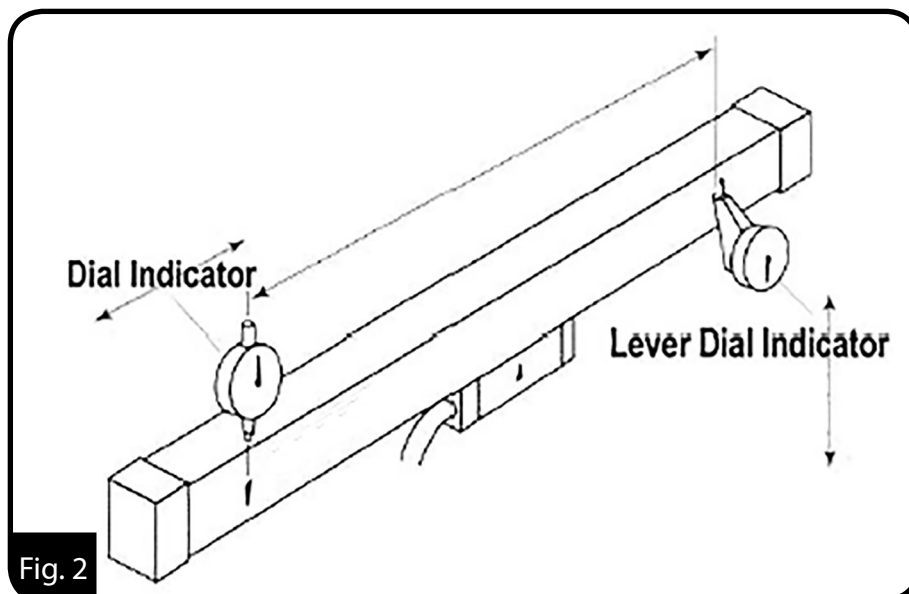

# SINO

## Mounting Position

4. The opening of the scale must **not** be installed as to be directly exposed to swarf, oil, water, dust or other foreign products. (Fig. 3)  
Covers provided should be installed.

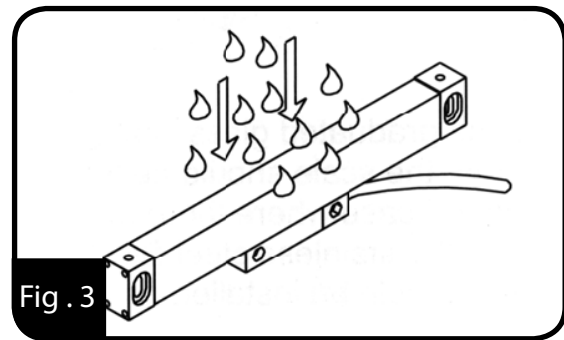

Fig. 3

## Backing Plates

5. In cases where machined flat surfaces are not available, optional backing plates should be used to provide a flat datum for the installation. (Fig. 4)

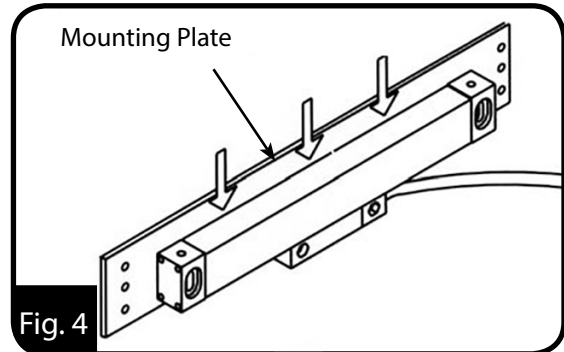

Fig. 4

## Cover Clearance

6. A clearance of at least 3.0mm between the scale and scale cover should be maintained. (Fig. 5)

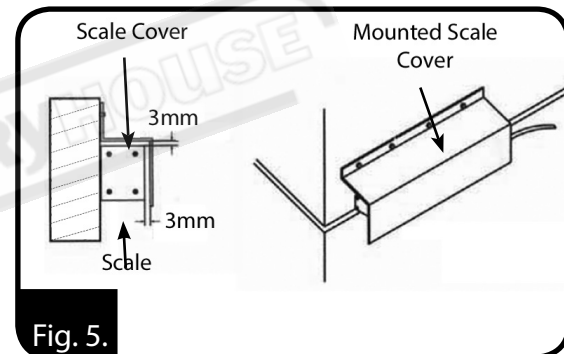

Fig. 5.

## Drilling and Tapping Holes

7. When drilling and tapping the holes be sure that the drill and tap are square to the cover. (Fig. 6)  
All tapped screw holes must have at least 6 threads to allow the screw to be firmly secured into the holes. When the screw is needed to secure a heavy load, the tapped holes must have at least 8 threads. After tapping, the holes must be deburred and cleaned

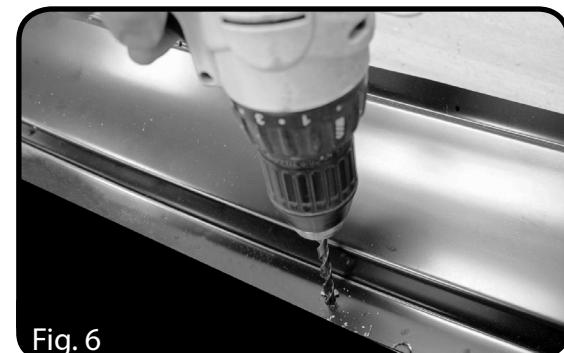

Fig. 6

## Securing Cable

8. All cables must be fixed, but allow for the maximum machine travel movements. Diagram (Fig. 7) recommends the minimum radius that should be used for bending the scale cable. Use the cable clamps supplied to secure the cables to the display arm.

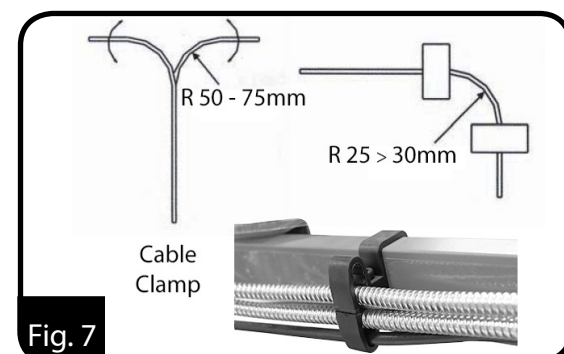
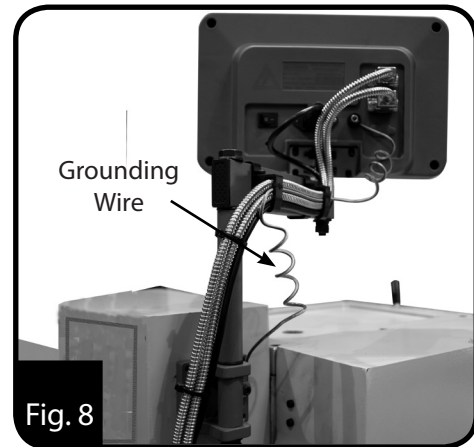
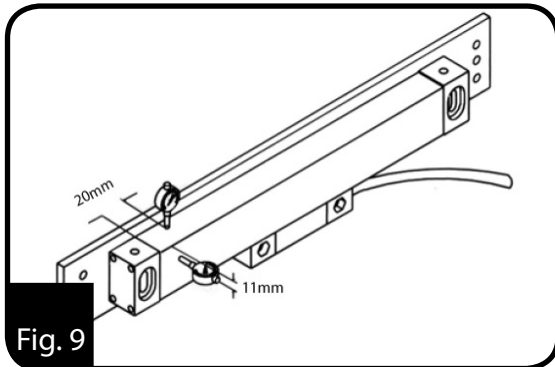

Fig. 7

# SINO

## Grounding & Earthing

9. Grounding / Earthing is very important for the noise immunity. The grounding wire must be attached between the metal body of the machine and the grounding pin on the back of the display unit to be effective. (Fig. 8)



## Final Alignment

10. The Horizontal and Vertical alignment measurement are taken at 20mm away from the scale ends as shown in the diagram. (Fig. 9)

## INSTALLATION STANDARDS & REQUIREMENTS

### 1. Requirements for the Mounting Surface

- If the scale mounting surfaces are not parallel to each other (ie. As per shown in figure A and B), the parallelism of the two mounting surfaces must be less than 0.1mm.
- If the mounting surfaces are perpendicular to each other (i.e. As per shown in figure C), the squareness of these two mounting surfaces must be less than 0.1mm. (Fig. 10)

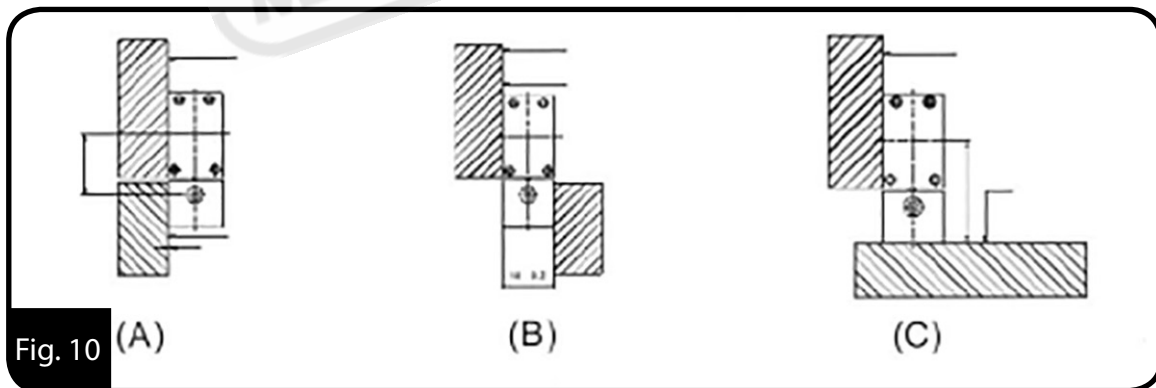

### 2. Scale Alignment

It is very important that the scale must be aligned parallel to the travel of the machine slide. For scale travel less than 950mm, the maximum parallel error between the scale and the machine slide must be less than 0.1mm – 0.15mm. For scale travel longer than 950mm, the maximum alignment parallelism error must be less than 0.15mm - 0.2mm. (Fig. 11)

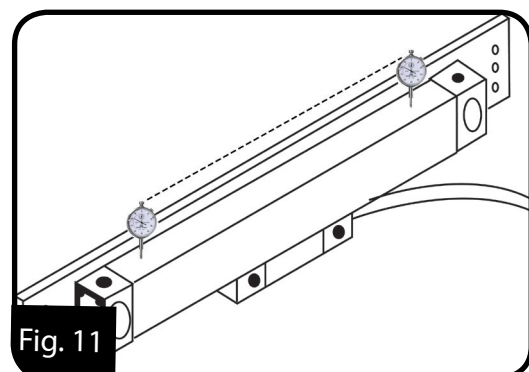



### INSTALLATION STANDARDS & REQUIREMENTS Cont.

#### 3. Clearances Between the reader head and scale body:

The clearance between the reader head and scale body must be kept between 0.8mm-1.5mm. The reader head must be less than 0.5mm parallel with the scale and can be set with feeler gauge to allow the reader head to move unrestricted along the scale. (Fig. 12)

#### Scale Direction

Before mounting the scales it is important that the scale reads in the correct direction.

The chart below indicates the reading that should be obtained when traveling in that direction. (Mill Fig.13, Lathe Fig.14)

**Note!** To reverse the scale direction refer page 6 of manual

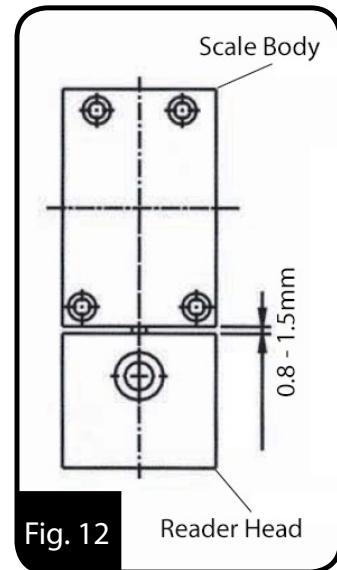

Fig. 12

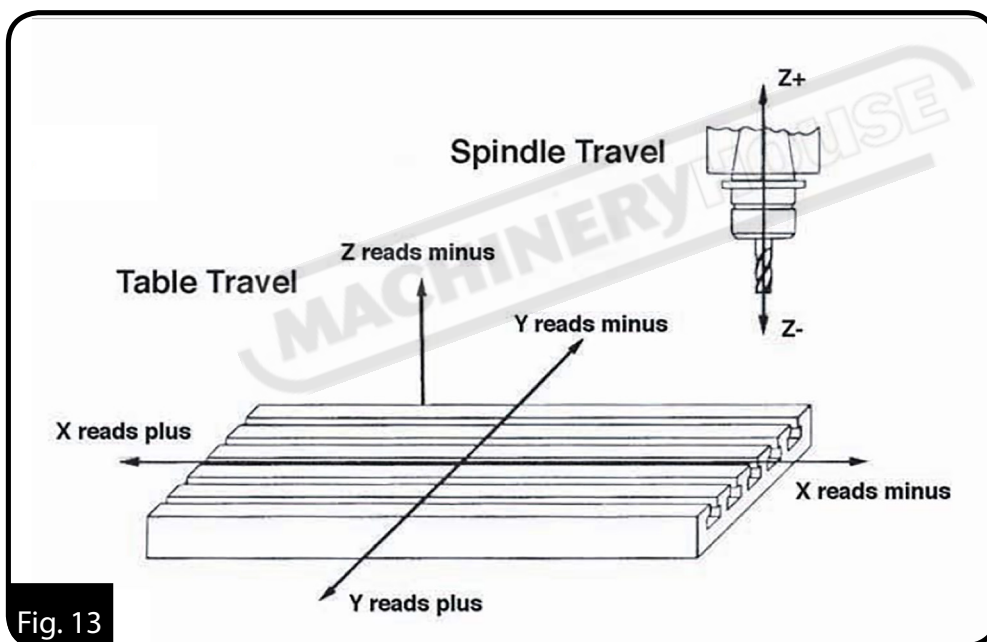

Fig. 13

Milling Machine Direction

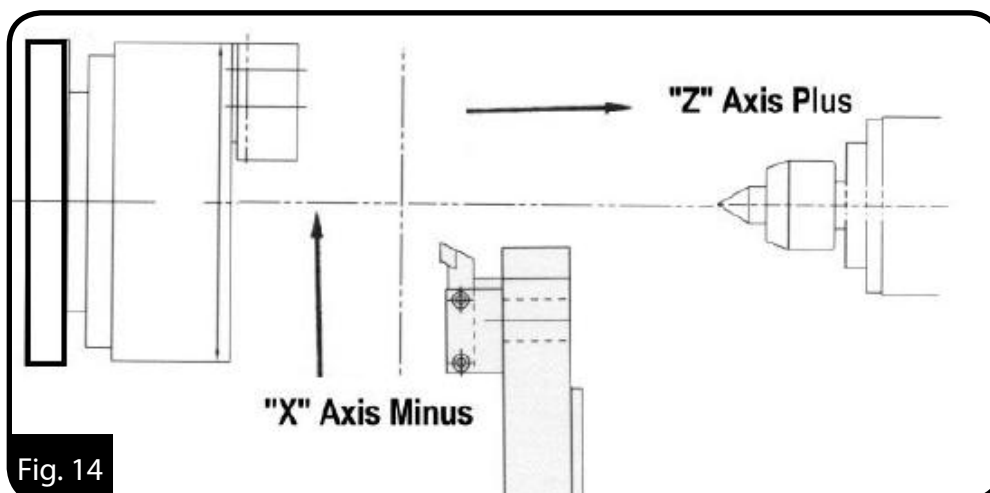

Fig. 14

Lathe Direction



## CHANGING THE SCALE DIRECTION.

After the scales have been installed it may be necessary to change the direction of the scale so that it reads correctly. E.G. If you are using the scale on a lathe, then the scale that reads the diameter must get smaller as the tool gets closer to the centre.

This is all controlled by the display unit in the "SETUP" section.



If the linear scale is installed as the figure below (facing operators):

Direction "0" means the display value will increase when scale moves from right to left and decrease when scale moves from left to right.

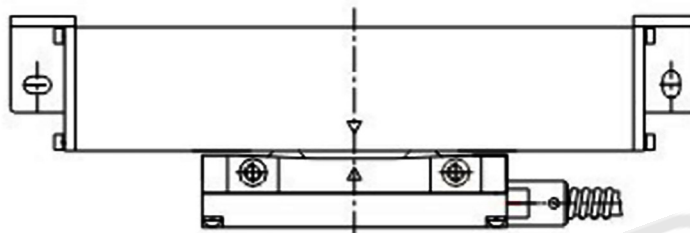

1. Enter "SETUP" and then press or until "DIRECT" appears in message window. Press !ENTER) to enter direction setup; X window, Y window and Z window will display "0" or "1" against them.



2. Select an axis by pressing the "X", "Y" or "Z" button and then press enter. This will display "0" or "1" against the "X" axis.



3. Using the or to change the display from "0" to "1" to change the direction of the scale. Once the change has been made press "enter" to confirm and save the change and exit the setup section.



# SINO

## FITTING THE "X" SCALE ON A MILLING MACHINE

One of the easiest ways to set up an "X" scale on a milling machine, if the side of the table is machined, is to clamp two parallels to the flat table surface that the table travels on and sit the scale on the parallels. Carefully drill and tap the holes to take the screws provided. (Fig. 15)

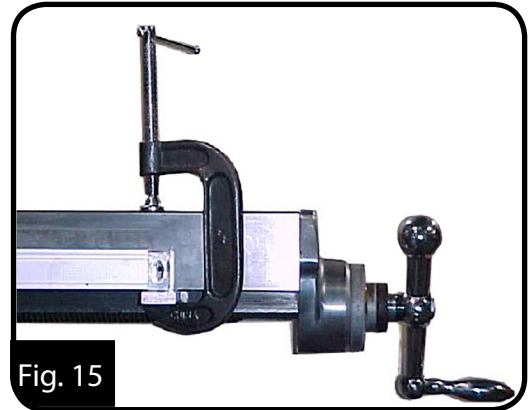

Fig. 15

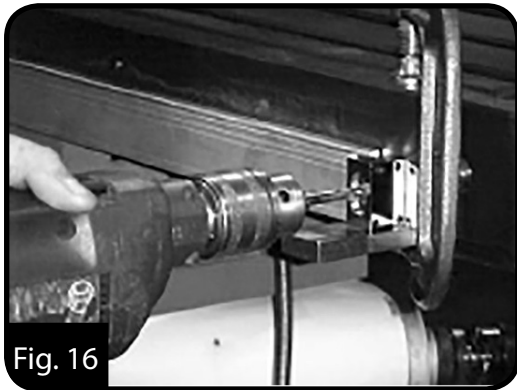

Fig. 16

When the scale is mounted then fix the reader head to the saddle, if necessary packing the head to ensure that it is parallel and in line with the scales. (Remove the Grey packing between the reader head and scale which allows for the correct clearance and holds the reader head parallel to the scale.) (Fig. 16)

Mount the cover over the scale, and drill and tap the holes to secure it to the table making sure that there is 3mm clearance between the cover and the scale. (Fig.17)



Fig. 17



Fig. 18

### FITTING THE "Y" AXIS SCALE.

If the surface is not machined, mount the backing plate and use the grub screws to adjust the backing plate, checking with a dial indicator until the scale is square and perpendicular to the machine slides. (Fig. 18)

Mount the scale on the backing plate using the pre-drilled holes, checking that the scale is parallel with the machine slide with a dial indicator. (Fig. 19)

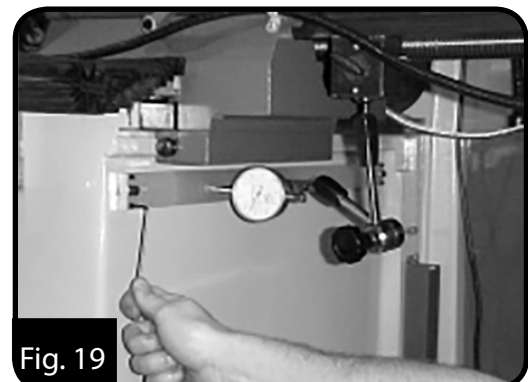

Fig. 19

# SINO



Fig. 20

After the scale is aligned to the axis, then drill and tap the saddle to suit the bracket provided and mount the bracket ensuring that the reader head is sitting correctly so that when the reader head is attached it will be square and parallel to the scale. (Fig. 20)

Mount the bracket on the saddle to take the reader head making sure that the reader head is in line and parallel to the scale. Secure the cable making sure to leave enough free cable to allow for the travel of the slide. (Fig. 21)

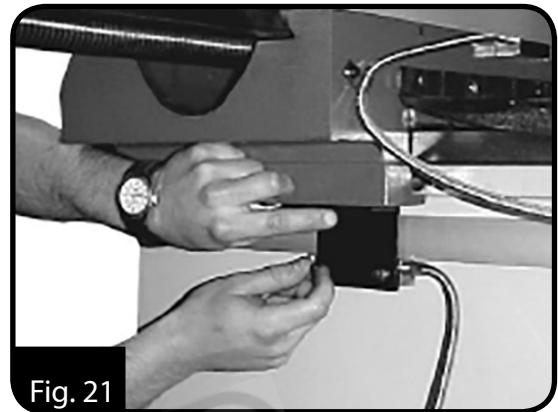

Fig. 21

## FITTING THE "Z" AXIS SCALE

Before mounting the scale ensure that it will read "+" as you wind the table down, increasing the distance from the table to the cutter



Fig. 22



Fig. 23



Fig. 24

The "Z" axis scale should be installed on the side of the column ensuring that the open side of the scale is away from direct swarf and coolant and that the travel is in the right direction "-" towards the spindle and "+" away from the spindle. The bracket (Fig. 22) is mounted off the knee, and around the scale (Fig. 23) to allow for the cover (Fig. 24) to protect the scale, where excessive coolant & swarf are present.



### LATHE INSTALLATION

To install a readout on a lathe the following tips can be used. To mount the cross slide scale select a flat surface that is suitable and clear of the traveling parts of the lathe.

The scale should be mounted ensuring that it is parallel and square to the slide. (Fig. 25)



Fig. 25



Fig. 26

When mounting the reader head if necessary pack the reader head (Fig. 27) so that it travels in line and square to the scale to avoid any damage to the scale. Testing for parallel can be done by either a dial indicator or a precision level. (Fig. 26) The cover must be fitted (Fig. 28)



Fig. 27



Fig. 28

The longitudinal scale should be mounted on the back of the Lathe (Fig. 29) with the open side of the scale facing down and must be parallel to the bed. The reader head is mounted to the saddle (Fig. 30) via the brackets provided. Some modification may be required for some lathes. Covers should be mounted over the slides. (Fig 30)

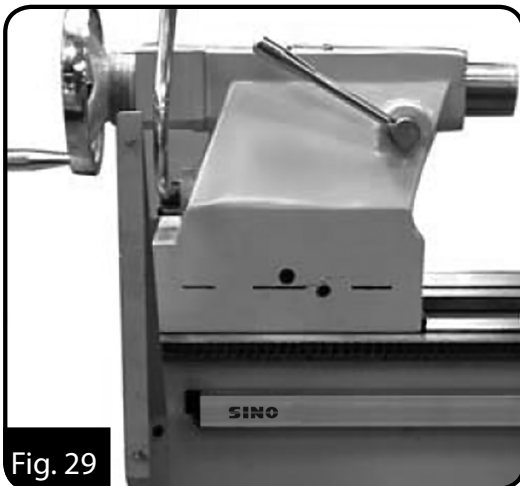

Fig. 29



Fig. 30

# SINO

## MOUNTING THE DRO

The Sino Digital Readout is supplied in two packs. The display unit (Fig. 31), lathe mounting kit (Fig. 32) and mill mounting kit. (Fig. 33)



Fig. 31

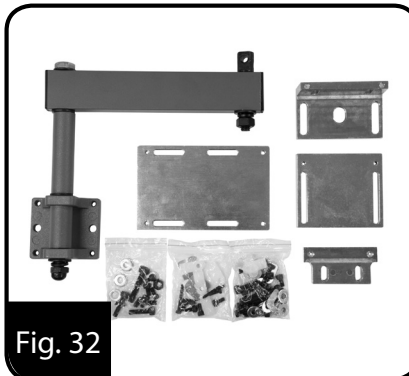

Fig. 32



Fig. 33

The display unit is supplied with two mounting plates but the 4 off M4 x 8mm Socket head cap screws (Fig. 34) are supplied with the mounting kit. (Fig. 32 & 33) There are two DRO mountings. One for a lathe (Fig. 35) and one for mills (Fig. 36) Either mounting kit can be used if more appropriate.

4 off M4 x 8mm  
Socket Head Cap screws

Fig. 34



Fig. 35

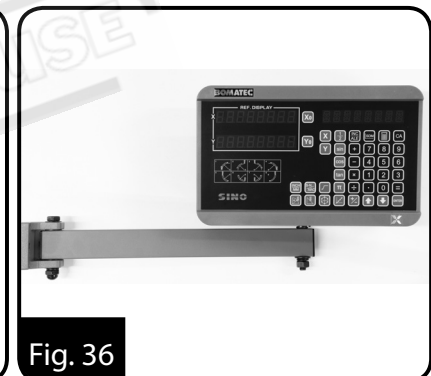

Fig. 36

The DRO is mounted to the bracket using the two angle brackets and the mounting pin and secured with the bolt supplied. (Fig. 37)

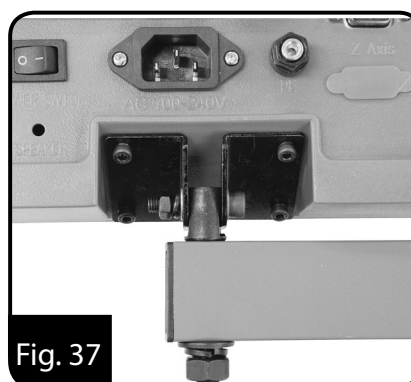

Fig. 37

### FINDING A SUITABLE MOUNTING POINT.

Before mounting the DRO find a suitable flat surface to anchor the bracket. Check that the movement of the DRO on the bracket will clear all items and is in a place where it can be read and operated easily.

Make sure that the cables attached to the DRO will reach with out being stretched and caught or tangled.



### NOTE:

Modification to brackets or reproducing of additional brackets or spacers may be required to suit your particular machine



**DIMENSIONS**

**Sino MK-300 Series Scales**

**L = Effective measuring length of scale**

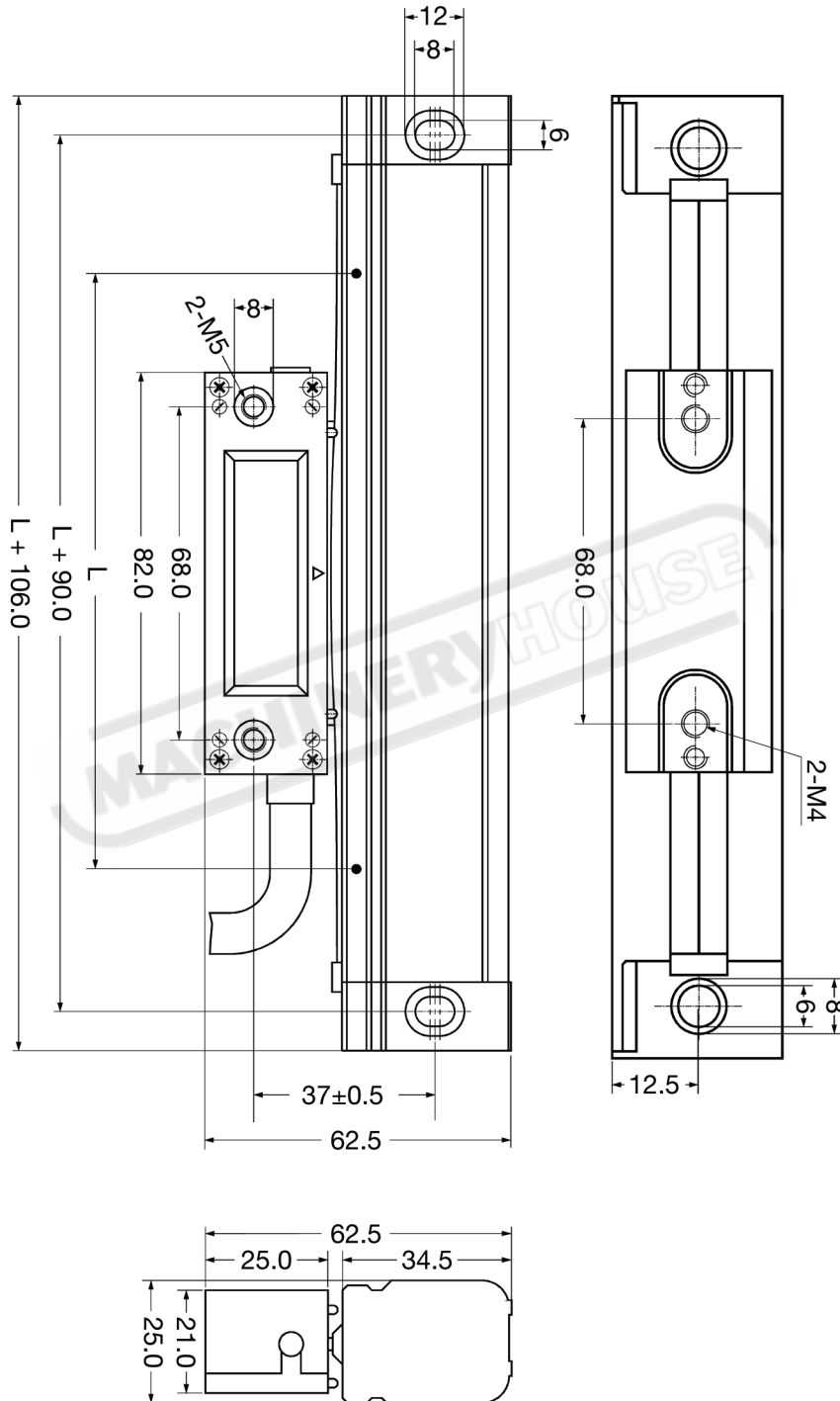



### DIMENSIONS

## Sino MK-500 Series Compact Scales

L = Effective measuring length of scale

